

The premier source of tooling, parts, and accessories for bench top machinists.



Model 4160 Speed Lathe Users Guide

from LittleMachineShop.com

© Copyright 2017 LittleMachineShop.com
All rights reserved.

Revision 1, July 2017

LittleMachineShop.com
<http://www.littlemachineshop.com>
396 W. Washington Blvd. #500, Pasadena, CA 91103
(800) 981-9663 • Fax (626) 584-5844

Contents

Introduction	4
Specifications	4
Safety Considerations	4
General Safety.....	4
Lathe Safety	4
Electrical Safety.....	5
Machine Safety	5
Component Identification	6
Accessories	7
Optional Accessories	7
Setup	7
Cleaning	7
Assembly	7
Setting Up and Using the Foot Switch.....	7
Speed Lathe Operation	8
Testing Operation.....	8
Replacing and Adjusting the Collet.....	8
Normal Lathe Operation	10
Maintenance	10
Lubrication.....	10
Replacing the Drive Belt	10
Changing Foot Switch Operation.....	11
Parts Diagram	12
Parts List	13
Assemblies	14
Wiring Diagram.....	15

Introduction

This user's guide covers care and operation of the Speed Lathe. Be sure to read and understand the safety guidelines presented in this book before using your Speed Lathe.

Specifications

Spindle taper	5C
Spindle speed	0-3200 RPM
Power requirements	120 V 60 Hz 10 Amps
Spindle motor output	1.1 hp (800 Watts)
Weight	106 lb (48 kg)

Safety Considerations

Always use common sense when using a power tool. Besides the general safety rules for any power tool, following also are specific considerations for the Speed Lathe.

General Safety

- Use common sense. Think through the results of your actions before you act.
- Understand the operation of the machine. Do not operate the machine if you do not know what is going to happen.
- Learn, don't experiment. Study, understand, and do things where you have a clear expectation of the outcome. Don't "see what will happen."
- You are responsible for your own actions. We can't be held responsible for your actions when you use the machine.

Lathe Safety

- Your Speed Lathe is a small lathe. Don't attempt jobs that are beyond its capacity.
- Check the workpiece after you place it in the chuck or other work holding device. Be sure it is secure before turning on the lathe.
- Don't wear loose clothing or jewelry when operating the lathe.
- Stop the spindle and make sure the machine is in a safe condition before:
 - Reaching into work area
 - Changing or adjusting tools
 - Changing or adjusting workpieces
 - Clearing chips or coolant

- Inspect cutting tools for sharpness, chips, and cracks before each use. Replace dull, chipped, or cracked cutting tools immediately.
- Handle cutting tools with care. Cutting edges are very sharp and can cause lacerations.
- Do not use unbalanced workpieces or fixtures in the spindle
- Remove all tools (wrenches, chuck keys, locking pins, and so on) from the spindle immediately after using them.

Electrical Safety

- Plug the machine into a grounded receptacle.
- Use caution when using liquids and electricity. Ensure that coolants and lubricants are kept away from high voltage electrical components.
- Disconnect all components from the power receptacle before servicing.
- In the event of a power outage, turn off all components to ensure that the machine does not restart unexpectedly.

Machine Safety

- Keep bystanders, children, and visitors a safe distance away while operating any power tool.
- Read the manual. Know the operation of every control before you attempt any operation of the machine.
- Make sure that all guards are in place and functioning before operating the machine.
- Check for damage and abnormal wear before operating the machine.
- Always wear safety glasses (side shields are recommended) that are ANSI Z87.1-2003 compliant.
- Wear hearing protection (ear plugs or ear muffs) when operating loud machines.
- Wear appropriate clothing; no rings, gloves, neckties, jewelry, or loose-fitting garments. Bind long hair or wear a hat.
- Do not use compressed air for cleaning machines. A shop vacuum works well and is much safer.
- Don't operate machinery while under the influence of drugs or alcohol.
- Ensure that your machines are well lit. Ensure that your shop is well lit, and have additional task lighting where appropriate.
- Maintain a clean and uncluttered work area.
- Avoid pinch points.
- Never leave a running machine unattended.
- Do not force or overload machinery.
- Use appropriate cutting tools with appropriate feeds and speed.

- Cutting tools get hot during use and can cause burns if handled inappropriately.
- Do not attempt to use workpieces that are too large or too heavy for the machine.
- Maintain your machine. Ensure that it is well-adjusted and in a safe state.
- Clear chips with a brush or other tool, never with your hands or with compressed air.
- Make sure the machine is on a flat, level surface that can support the weight of the machine plus fixtures, vise, and workpiece.
- Clamp work securely. Cutting forces are significant and can turn workpieces that are not secured into projectiles.
- Be aware that chips and dust from some materials (magnesium, for example) are flammable. Understand the materials you are using.

Component Identification

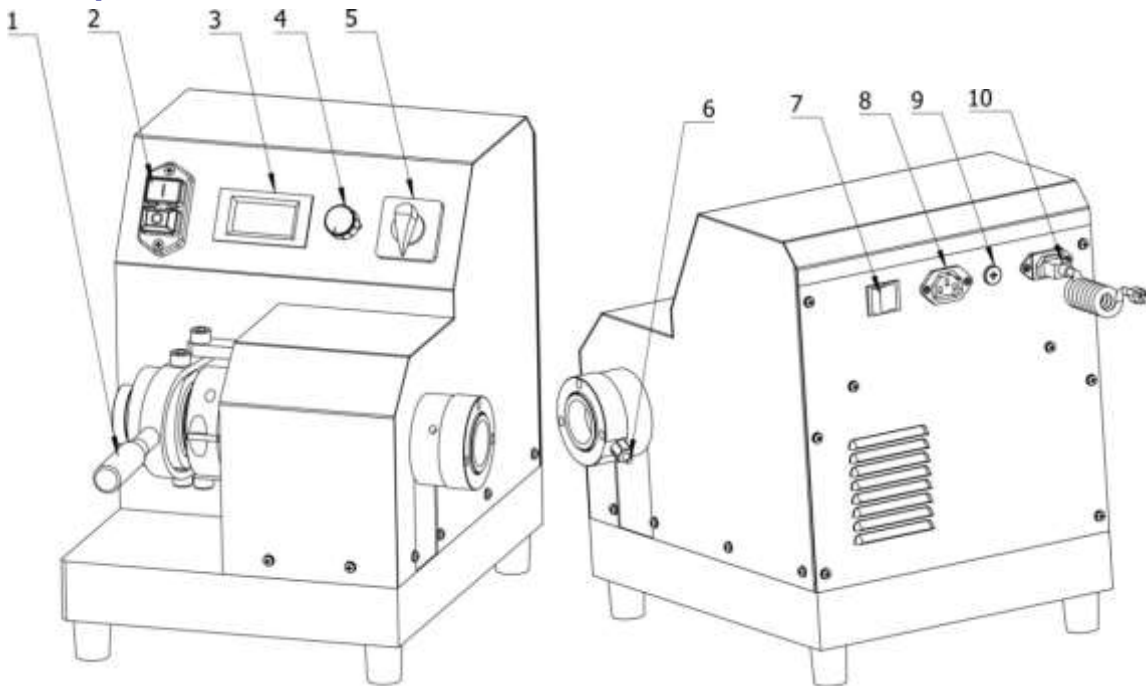

1. Locking/releasing handle
2. Power switch
3. Speed display (rpm)
4. Speed control knob
5. Forward/reverse switch

6. Spindle key
7. Run/foot switch
8. Foot switch socket
9. Fuse
10. Power cord

Accessories

The following accessories are included with the Speed Lathe.

- Foot switch
- Hex wrenches: 3 and 5 mm
- 5/8" 5C spring collet
- This instruction manual

Optional Accessories

5C collets are available for holding work in a variety of shapes, sizes, and materials.

- Round collets are available in metric sizes from 1-28 mm and imperial sizes from 1/32" to 1-1/8".
- Square collets are available from 3-19 mm and 1/8" to 3/4".
- Hex collets are available from 3-22 mm and 1/8" to 7/8".
- Collet materials include steel, copper, and nylon.

Setup

Take a few minutes to clean your new Speed Lathe and connect the foot switch, and you're ready to go.

Cleaning

The unpainted surfaces are coated with a waxy oil to protect the Speed Lathe from corrosion during shipment. Follow this procedure to remove the oil:

1. Wipe most of the oil off with rags or paper towels.
2. Clean the surfaces with mineral spirits (paint thinner).
3. Coat the surfaces with oil to prevent rust. Virtually any oil will do; we recommend way oil or motor oil. (A synthetic motor oil such as Mobil 1 works well.)

Assembly

Your Speed Lathe comes fully assembled and ready to run. If you plan to use the foot switch to control the lathe, you'll need the following information.

Setting Up and Using the Foot Switch

You can start and stop the lathe using the foot switch instead of the front panel controls. To enable this:

1. Plug the foot switch into the foot switch socket on the back of the lathe.
2. Set the run/foot switch to Foot.

When the run/foot switch is set to Foot, you use the front panel controls to set the spindle speed and direction, as explained in the following sections. To make it run:

- The power switch must be on
- The speed control knob must be turned to a non-zero speed
- The forward/reverse switch must be set to ↶ (reverse) or ↷ (forward)
- You must press the foot switch pedal

Speed Lathe Operation

This machine presents serious injury hazards to untrained users. Read through this entire manual to become familiar with the controls and operations before starting the machine!

Testing Operation

Before you apply power, turn the knurled rolling handle by hand to be sure the spindle turns freely.

Then, to run the lathe for the first time:

1. Set the forward/reverse switch to the neutral (0) position.
2. Press the green | button on the power switch to turn on the power. The speed display should light up.
3. Turn the speed control knob counterclockwise until it clicks.
4. Turn the forward/reverse switch to forward.
5. Slowly turn the speed control knob clockwise. The spindle should begin rotating.
6. Rotate the speed control knob to its highest setting. After a few moments, the speed display should show a speed approaching the maximum of 3200 RPM.
7. Repeat steps 3 through 6, except this time turn the forward/reverse switch to reverse.

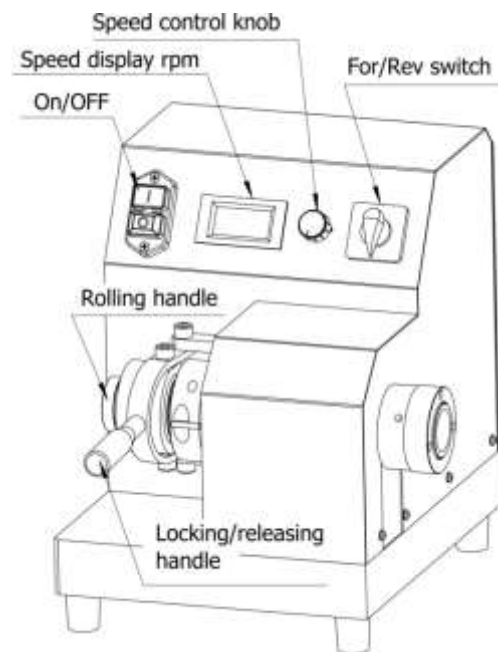

Replacing and Adjusting the Collet

The Speed Lathe includes a 5/8" collet. You might want to replace it with a different 5C collet.

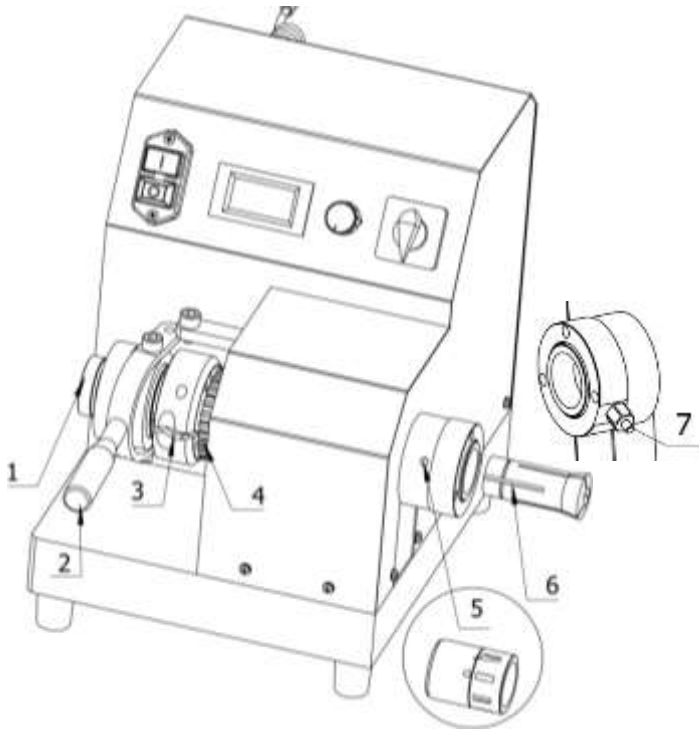

To remove a collet, follow these steps:

1. Move the locking/releasing lever (number 2 in the figure above) to the right.
2. Rotate the knurled rolling handle (1) until the dog (3) is accessible.
3. Press the left side of the dog to disengage the clutch (4).
4. Turn the rolling handle counter-clockwise to unscrew the collet.

Chris' Tip

If the collet and the spindle rotate instead of the collet unscrewing, press the spindle locking pin (7) as you slowly turn the rolling handle. At some point in the rotation, the pin will drop into a hole and prevent the spindle and collet from turning, thereby allowing you to unscrew the collet with the rolling handle.

You can also look in the observation hole (5). When a hole in the spindle becomes visible, the spindle is in the correct location to engage the spindle locking pin.

5. Continue turning the rolling handle counter-clockwise until the collet is loose, and then pull out the collet (6).

To install a collet:

1. Follow steps 1 through 3, above.
2. Insert a collet (6) in the spindle opening.
3. Use the observation hole (5) to find the hole in the spindle and then press the spindle locking pin (7) to prevent the spindle from turning.
4. Turn the knurled rolling handle (1) clockwise to tighten the collet.

5. Press the right side of the dog (3) into a groove in the clutch (4) to engage the clutch.

To adjust a collet so that it properly grips your workpiece:

1. Move the locking/releasing lever (2) to the right.
2. Insert your workpiece in the collet and move the locking/releasing lever to the left. Check to see if the workpiece is held tightly. If you need to adjust it, continue...
3. Move the locking/releasing lever to the right and remove the workpiece.
4. Using the rolling handle (1), turn the spindle until you can lock it with the spindle locking pin (7).
5. Press the left side of the dog (3) to disengage the clutch (4), and then turn the rolling handle counter-clockwise to loosen the collet on the workpiece, or clockwise to tighten it.
6. When you have it where you want it, press the right side of the dog into a groove in the clutch.

Normal Lathe Operation

With an appropriately sized collet in the spindle, push the locking/releasing handle to the right to open the collet. Insert your workpiece in the collet, push the locking/releasing handle to the left to lock the workpiece in place.

Each time you use the lathe, you should first turn the knurled rolling handle by hand to be sure the spindle turns freely. Then, with the power on, use the speed control knob and forward/reverse switch to turn the workpiece.

You can change the motor direction at any time and at any speed that safety allows. The motor will make a controlled stop or a controlled change of direction.

Maintenance

Maintenance requirements for the Speed Lathe are few. Simply keep it clean and it should continue running well for a long time.

Lubrication

All bearings in the Speed Lathe are lubricated for life. Therefore, no regular lubrication is required. However, we recommend keeping oil on all machined surfaces to prevent rust. Virtually any oil will do; we recommend way oil or motor oil. A synthetic motor oil such as Mobil 1 works well, as it maintains a good surface film between applications.

Replacing the Drive Belt

If the drive belt fails, follow these steps to replace it.

1. Unplug the power cord.

2. On the right side, remove the spindle collar, which is held in place by three screws. You'll need a 3-mm hex wrench to remove the screws.
3. Remove the screws that attach the housing to the base. You'll need to remove:
 - 2 screws on the left side, toward the back
 - 3 screws below the spindle, on the left side
 - 2 screws on the front of the housing
 - 5 screws along the base of the right side

Note: You don't need to remove any screws from the back of the machine.
4. Lift off the housing and tilt it toward the back of the machine. Note that the electrical connections through the back cover prevent you from removing it altogether.
5. Remove the four screws at the base of the cover plate on the right side of the machine, and then remove the heavy plate.
6. Loosen the four bolts that secure the motor in place.
7. Slide the motor forward and replace the belt.
8. Adjust the belt tension and then replace each of the covers and screws you removed.
9. Replace the spindle collar. Note that, when viewed from the right side, the spindle locking pin should be in the four o'clock position.
10. Before you apply power, turn the knurled rolling handle by hand to be sure the spindle turns freely.

Changing Foot Switch Operation

The foot switch can be configured so that it is normally on. With this setup, the spindle runs constantly (assuming the other three switches are set properly, as described above) and stops only when you depress the foot switch or turn off one of the other switches. To configure the switch this way:

1. Disconnect the foot switch from the Speed Lathe.
2. Remove the four screws in the top of the foot switch.
3. Move the white wire from the Always Open terminal to the one marked Always Closed.
4. Be sure the Speed Lathe power is off, and then plug the foot switch into the foot switch socket.

Parts Diagram

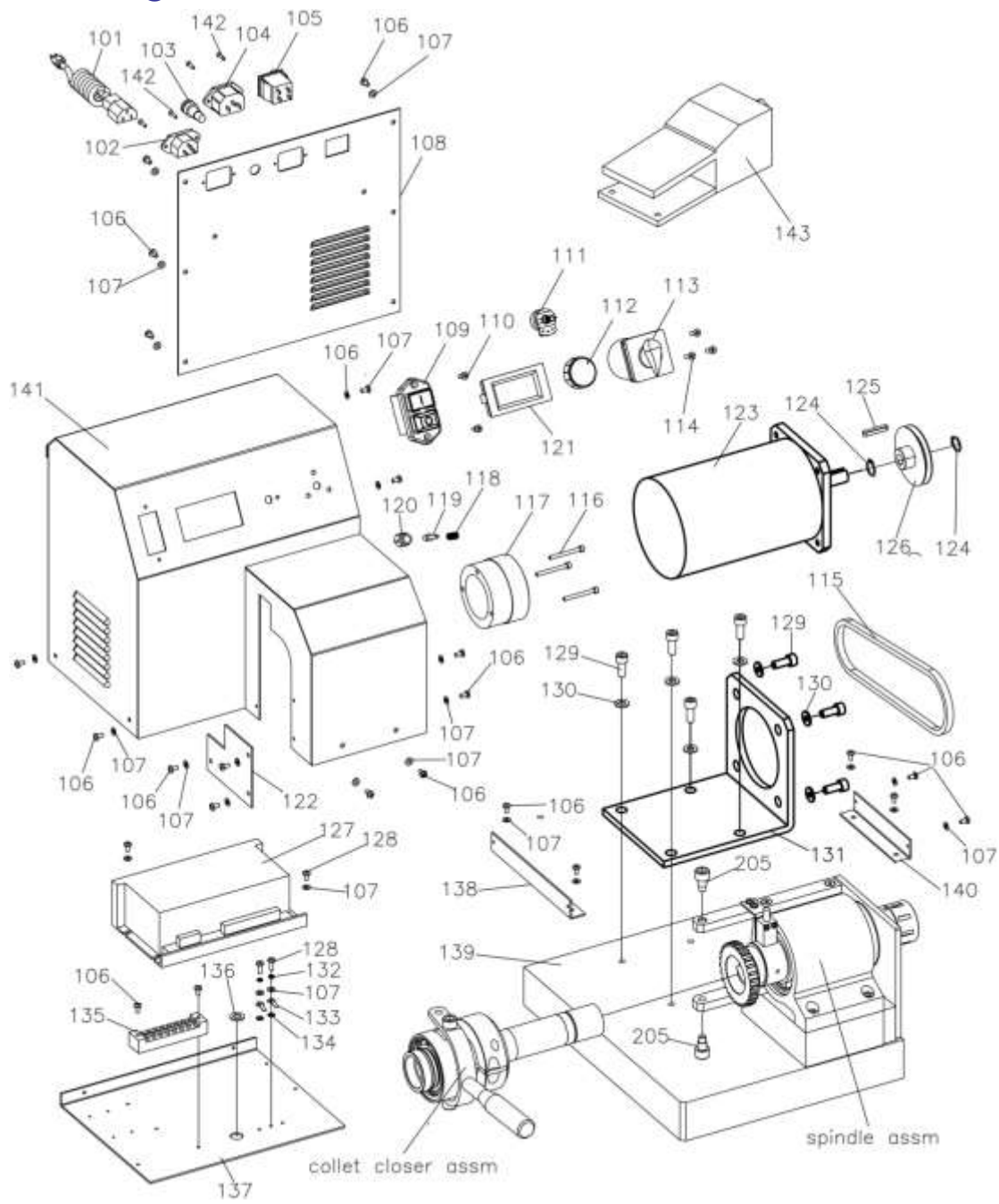

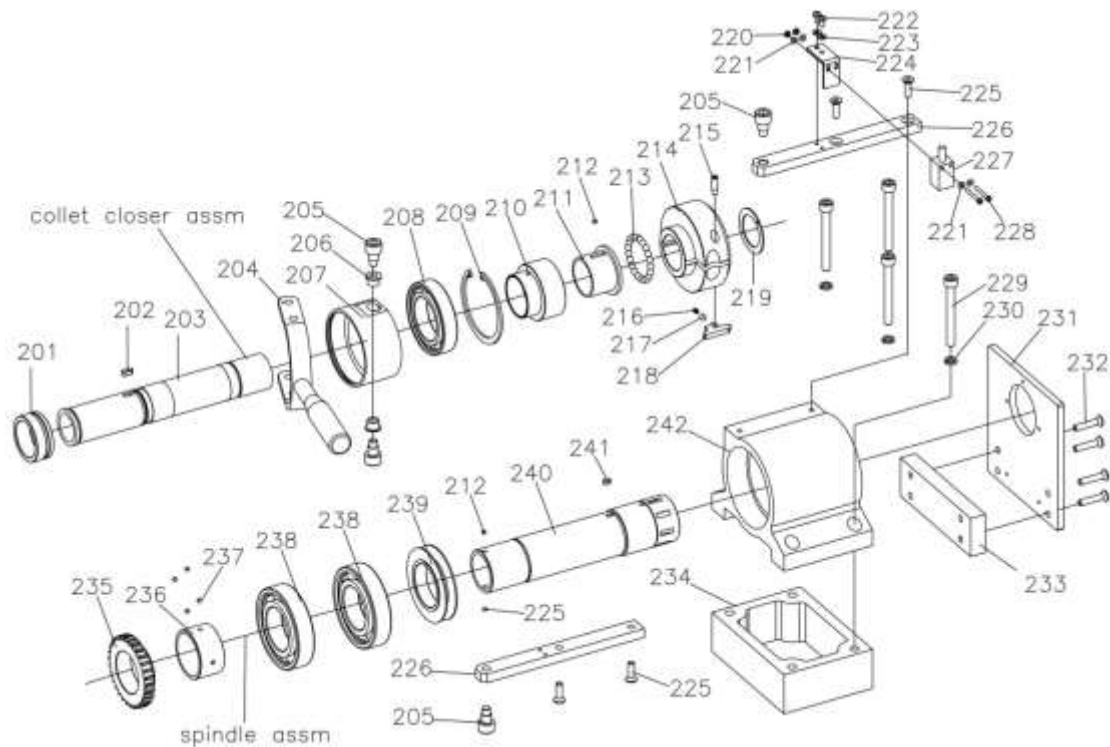

Parts List

Item	Description	Qty.
101	Power cord	1
102	M16 plug sleeve	1
103	MF527 fuse seat	2
104	SS-8B power socket	1
105	Speed change switch	1
106	Screw M4 x 8	21
107	Washer	25
108	Back cover	1
109	KJD17B electromagnetic switch	1
111	WH24-2 potentiometer	1
112	Knob	1
113	ZH-HC-2 alternation switch	1
115	0-560 belt	1
116	Screw M4 x 40	3
117	Brake ring	1

Item	Description	Qty.
118	Compressing spring	1
119	Locating pin	1
120	Bolt	1
121	Speed digital display	1
122	Left guard board	1
123	800W motor	1
124	External circlip	2
125	Key	1
126	Motor pulley	1
127	Circuit board	1
128	Screw M4 x 12	3
128	Screw M4 x 12	8
129	Screw M8 x 20	7
130	Flat washer	4
131	Motor seat	1
132	Spring washer	2

Item	Description	Qty.
133	Ø4 earth tag	2
134	Internal tooth lock washer	2
135	Binding post	1
136	Ø12 protective ring	1
137	Electrical supporting plate	1
138	Angle iron II	1
139	Worktable	1
140	Angle iron	1
141	Motor guard	1
142	Screw M3 x 12	2
143	H3-6 foot switch	1
201	Sleeve	1
202	Key	1
203	Tension shaft	1
204	Tension handle	1
205	M10 x 16 Homemade screw	4
206	Nylon washer	2
207	Bearing sleeve	1
208	Rolling bearing	1
209	Circlips for holes-type	1
210	Bearing inner sleeve	1
211	Thrust sleeve	1
212	Ø4 ball	3
213	Ø6.35 ball	21
214	Locking sleeve	1
215	Homemade screw	1
216	Spring	1
217	Center	1
218	Lock hook	1
219	Plastic ring	1

Item	Description	Qty.
220	Hex nut M3	2
221	Flat washer	4
222	Screw M4 x 8	2
223	Flat washer	2
224	Installation board of the tachometer probe	1
225	Screw M6 x 20	4
226	Support bar	2
227	Tachometer probe	1
228	Screw M3 x 25	2
229	Screw M8 x 70	4
230	Spring washer	4
231	Installation board	1
232	Screw M6 x 30	4
233	Thick pad	1
234	Pad	1
235	Divided wheel	1
236	Wrapped bushes	1
237	Magnetic iron	4
238	Ball bearing	2
239	Spindle pulley	1
240	Spindle	1
241	Key	1
242	Spindle box	1

Assemblies

P/N	Description
20100	Spindle assm
20200	Collet closer assm

Wiring Diagram

